

- CATERPILLAR
- CHRYSLER
- CONTINENTAL
- CUMMINS
- DETROIT • DEUTZ
- FIAT • FORD • GM
- ISUZU • KOMATSU
- KUBOTA • MAZDA
- MERCEDES
- MITSUBISHI
- NISSAN • PERKINS
- PEUGEOT
- RENAULT
- TOYOTA
- VOLKSWAGEN
- VOLVO
- WAUKESHA
- YANMAR

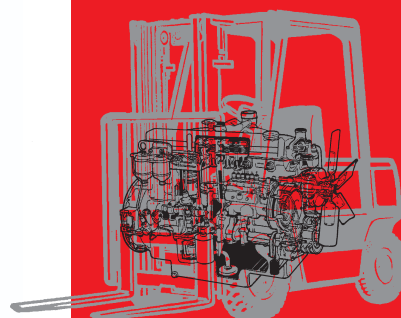

PIÈCES POUR MOTEURS THERMIQUES

Pour nos dernières mises à jour catalogue et toute information sur MANUTRANS : www.manutrans.ch

PIÈCES POUR MOTEURS THERMIQUES : VUE ÉCLATÉE & NOMENCLATURE

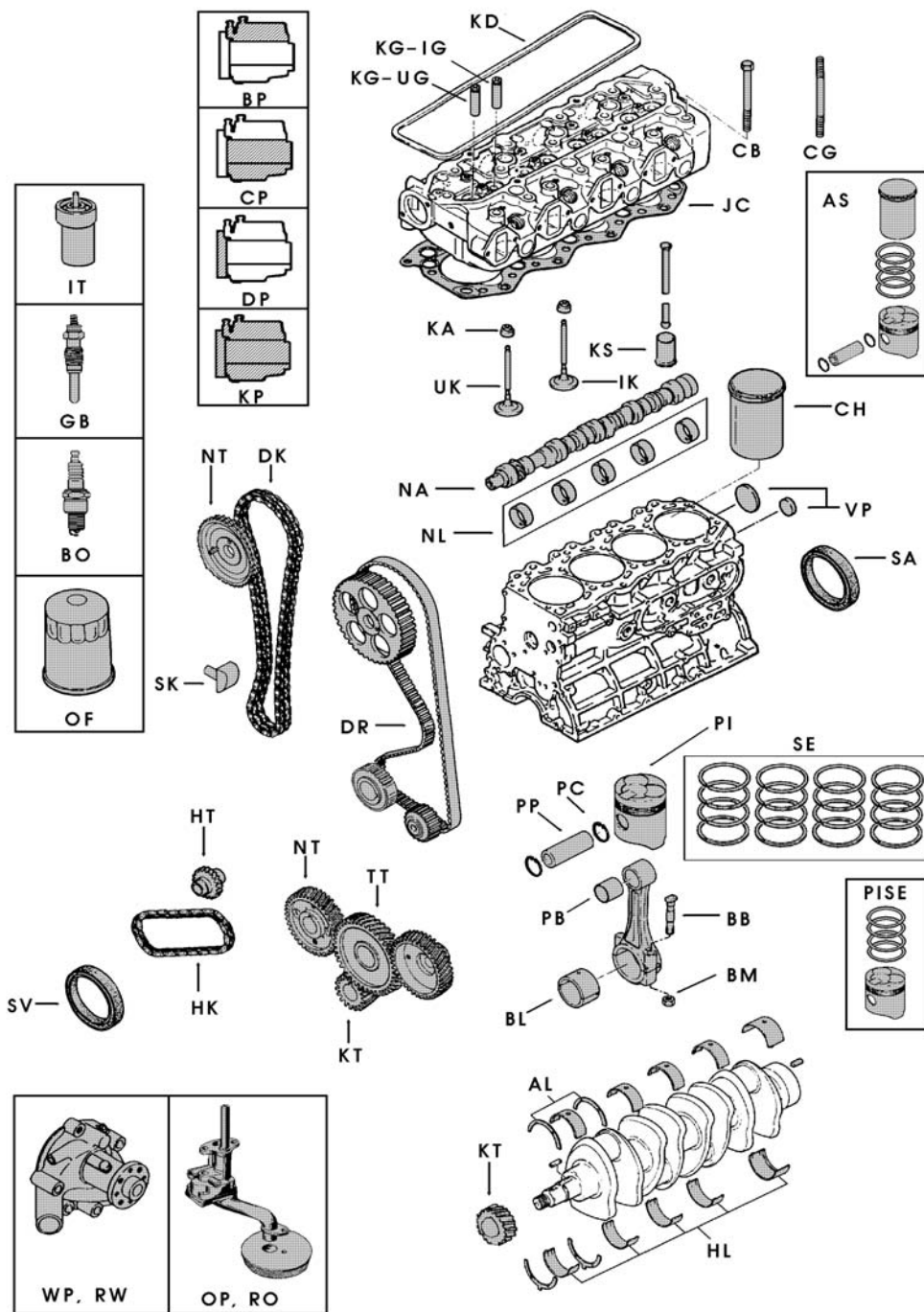

AL	Coussinets latéraux
AS	Ens. chemise (piston, segments, chemise)
BB	Vis de bielle
BL	Coussinets de bielle
BM	Ecrou de bielle
BO	Bougie
BP	Kit de rodage
CB	Boulon de culasse
CG	Goujon de culasse
CH	Chemise
CP	Kit de joints inférieurs
DK	Chaîne de distribution
DP	Kit de joints de distribution
DR	Courroie de distribution
GB	Bougie de préchauffage
HK	Chaîne d'entraîn. de pompe hydraulique
HL	Coussinets de paliers

HT	Pignon d'entraîn. de pompe hydraulique
IG	Guide de soupape d'admission
IK	Soupape d'admission
IT	Nez d'injecteur
JC	Joint de culasse
KA	Joint de queue de soupape
KD	Joint de cache soupape
KG	Guide de soupape d'ad. / d'éch.
KP	Kit de joints complet
KS	Poussoir de soupape
KT	Pignon de vilebrequin
NA	Arbre à cames
NL	Coussinets d'arbre à cames
NT	Pignon d'arbre à cames
OF	Filtre à huile
OK	Chaîne d'entraînement de pompe à huile
OP	Pompe à huile

PB	Bague de bielle
PC	Bague d'arrêt d'axe de piston
PI	Piston (avec / sans axe)
PISE	Piston (avec / sans axe)+ kit de segments
PP	Axe de piston
RO	Kit réparation de pompe à huile
RW	Kit réparation de pompe à eau
SA	Joint spi de vilebrequin, arrière
SE	Segments
SK	Tendeur de chaîne
SV	Joint spi de vilebrequin, avant
TT	Pignon flotteur
UG	Guide de soupape d'échappement
UK	Soupape d'échappement
VP	Kit de pastilles de désablage
WP	Pompe à eau

MOTEURS

• **CATERPILLAR :**
I404

• **CONTINENTAL :**
F135
F163
F227
F245
G193
Y112
TM20
TM27
TMD27

• **DEUTZ :**
F3L913G
GF3L913
F3 / 4 / 6 / L912 (W)

• **FIAT :**
8035-05-359
8045-05-359
8141-67-200
M705.19.149A1000
M205.16AA.149A000
8055.05.250

• **FORD :**
4-172
4-192

• **GM :**
4181
4153
6250
V6-4,3
2,2L

• **ISUZU :**
C240
C221
4FA1
4FE1
DA220
4JBI
G201
4JG2

• **KOMATSU :**
4D95
6D95
4D94E
6D105-I
4D105

• **MAZDA :**
XA
VA

UA
FE
HA
ZB
F2
TM

• **MERCEDES :**
OM314

• **MITSUBISHI :**
4DQ5(0)
S4E
S4E2
S6E
S6E2
4G33
4G52
4G53
4G54
S4S
4G64
4G63
KE42
4G15
S4Q2
4DQ7
4G41
6G72
KE46
4G15
S6S
S6K

• **NISSAN :**
SD22
SD25
SD33T
J15
H20
D11
Z24
A15
A12
H25
TD27
BD30
H15
H30
TB42
TD42
P40

• **PERKINS :**
4.236
4.203
4.2482
4.108

6.354
6.3544
1004.4
903-27
4.203.2
D3.152
1006.6

• **PEUGEOT :**
XD3P
XDP 4.88
XDP 4.90
XC7P
XNIP

• **TOYOTA :**
3P
4P
1Z
5R
5P
2J
4Y
5K
1DZ
11Z
2H
H
V1502
VT1502
V1512
2Z
V1512T
F
2F
3F
12Z
14Z
13Z

• **VOLVO :**
TD61 AW
TD71 AW
TD100 G

• **WAUKESHA :**
D155G
D176G



**MANUTRANS propose
des pièces pour tous les
moteurs listés ci-dessus.**

PIÈCES POUR MOTEURS THERMIQUES

Pour nos dernières mises à jour catalogue et toute information sur MANUTRANS : www.manutrans.ch

PRÉSENTATION DE NOTRE CATALOGUE DE PIÈCES POUR MOTEURS THERMIQUES

Engine parts used for: MITSUBISHI 4G33			
TYPE: Gasoline 4 Cyl. Bore: 73 mm		IN: MITSUBISHI CLARK	
		Nr. 6	
PART	REFERENCE	REMARKS	Qty./eng.
	PI 272006SIDA (STD, 025, 050, 075, 100) PI 272006SIDB (STD, 050, 075, 100) SE 272006SIDA (STD, 025, 050, 075, 100) SE 272006SIDB (STD, 050, 075, 100)	 A: first & sec. ring. Thickn= 1.5mm third ring. Thickn= 4 mm B: first & sec. ring. Thickn. 2mm third ring. Thickn.= 4 mm	4 4 1 1
	IK 272006A IK 272006B UK 272006A UK 272006B IG 272006005 (005, 025, 050) UG 272006005 (005, 025, 050)	A: length = 106 mm intake B: length = 103,5 mm intake A: length = 102,5 mm exhaust B: length = 100 mm exhaust intake exhaust	 A B
	HL 272006SIDA (STD, 025, 050, 075) HL 272006SIDB (STD, 025, 050, 075) 4BL 272006STD (STD, 025, 050, 075, 100, 125, 150)	STD shaft dia. 57,000 57,000 45,000 	1 1 1
	KP 272006A (#, O) overh. gskt. kit KP 272006B (#, O) overh. gskt. kit KP 272006C (#, O) overh. gskt. kit KP 272006D (#, O) overh. gskt. kit BP 272006 with JC272006C JC 272006A JC 272006B JC 272006C JC 272006D KA 272006 SV 272006 SA 272006 KD 272006A KD 272006B KD 272006C	A: for an engine with chain gasket kit valve regrind KDA KDB KDC KDE KFE KGE KHE KIE KJE KKE KLE KME KNE KOE KPE KQE KRE KSE KTE KUE KVE KWE KXE KYE KZE KAE KBE KCE KDE KFE KGE KHE KIE KJE KKE KLE KME KNE KOE KPE KQE KRE KSE KTE KUE KVE KWE KXE KYE KZE	 A B C D

For any other engine parts please contact us!

Engine parts used for: MITSUBISHI 4G33			
TYPE: Gasoline 4 Cyl. Bore: 73 mm		IN: MITSUBISHI CLARK	
		Nr. 6	
PART	REFERENCE	REMARKS	Qty./eng.
	CB 272006		4
	VP 272006		4
	BB 272006 BM 272006		1
	OP 272006A RO 272006A RO 272006B RO 272006C WP 272006A WP 272006B	 A B, C h B, C h = 11 mm C, h = 13 mm ROB, ROC Complete oil pump not serviced.	1 1 1 1 1 1
	NA 272006A NA 272006B NT 272006A NT 272006B KT 272006A KT 272006B KT 272006C KT 272006D KT 272006E	for a belt for a chain A: for belt type A B: for belt type B For belt type A Chain -S/N 300410 (Chain) S/N 300411- (Chain) For belt type B Tensioner for a belt Tensioner for a chain A: B: KTC, KTD KTB DRA DRB NTA NTB KTA KTE SKA	 A B KTC, KTD KTB DRA DRB NTA NTB KTA KTE SKA
	OF 272006A OF 272006B OF 272006C	D = 92, h = 103 mm D = 94, h = 78 mm D = 84, h = 76 mm	 A B C
	RO 272006A RO 272006B	W14EX-U W16EX-U	1 1

For any other engine parts please contact us!

Ceci n'est qu'une sélection de pièces disponibles dans notre catalogue. Pour toute autre pièce, demandez nous une offre

Engine parts used for: MITSUBISHI 4D54			
TYPE: Diesel 4 Cyl. Bore: 94 mm		IN: MITSUBISHI CLARK	
		Nr. 2	
PART	REFERENCE	REMARKS	Qty./eng.
	PI 272002SIDA (STD, 025, 050) PI 272002SIDB (STD, 025, 050) PP 272002 PC 272002 SE 272002STD (STD, 025, 050) CH 272002	A: h = 98,5 mm (A & B: without piston pin and snap rings) B: h = 90,0 mm piston pin snap ring	4 4 4 8 1 4
	IK 272002A IK 272002B UK 272002A UK 272002B KS 272002 KG 272002	Seat angle intake IKA, UKA = 45° intake IKB, UKB = 60° exhaust exhaust	 Seat angle
	1HL 272002SID (STD, 025, 050, 075, 100) 1AL 272002SID (STD, 015, 030, 045) 1BL 272002SID (STD, 025, 050, 075, 100) PB 272002	STD shaft dia. 75,000 82,250 57,980 28,000 STD thickn. 2,450	10 3 8 4
	KP 272002A kit KP 272002B kit BP 272002 JC 272002 KA 272002 SA 272002A SA 272002B SV 272002A SV 272002B KD 272002	A: No oil-seals and valve seals B: No oil-seals and valve seals gasket kit valve regrind gasket cyl. head valve seals Gasket inj. pump A: seal rear: for a wet clutch B: seal rear: for a dry clutch A: oil seal front: 78 x 55 x 12 mm B: oil seal front: 68 x 45 x 12 mm gasket valve cover	 A B

For any other engine parts please contact us!

Engine parts used for: MITSUBISHI S4E			
TYPE: Diesel 4 Cyl. Bore: 94 mm		IN: MITSUBISHI CLARK	
		Nr. 2	
PART	REFERENCE	REMARKS	Qty./eng.
	CB 272002		4
	VP 272002		4
	BB 272002 BM 272002		1
	OP 272002 RO 272002 WP 272002A WP 272002B RW 272002	 A: No oil seal, with oil nipple B: With oil seal, no oil nipple	1 1 1 1 1
	NA 272002 NT 272002 KT 272002 TT 272002		1 1 1 1
	OF 272002		1
	G8 272002A G8 272002B IT 272002A IT 272002B	22,5 V, M10, total length= 102 mm 22 V, M10, total length = 85 mm A: h = 27 mm B: h = 17 mm	 A B

For any other engine parts please contact us!

PIÈCES POUR MOTEURS THERMIQUES

Pour nos dernières mises à jour catalogue et toute information sur MANUTRANS : www.manutrans.ch

PRÉSENTATION DE NOTRE CATALOGUE DE PIÈCES POUR MOTEURS THERMIQUES

Engine parts used for: MITSUBISHI S4S			
TYPE: Diesel		IN: MITSUBISHI	
4 Cyl.		Nr. 10	
Bore: 94 mm			
PART	REFERENCE	REMARKS	Qty./eng.
	PI 272010STD (STD, 050) PP 272010 PC 272010	(without piston pin and snap rings) piston pin snap ring	4 4 8
	1SE 272010STD (STD, 050) CH 272010		4 4
	IK 272010 UK 272010	intake exhaust	
	KS 272010 KG 272010		
	2HL 272010STD (STD, 025, 050, 075) 1AL 272010STD (STD, 015, 030) 1BL 272010STD (STD, 025, 050, 075) PB 272010		5 3 8 4
	KP 272010 (O) JC 272010 KA 272010 SA 272010A SA 272010B SV 272010 KD 272010	overhaul gasket kit without oil-seals gasket cylinder head valve seals oil seal rear for wet clutch oil seal rear for dry clutch oil seal front gasket valve cover (O) = With valve seals	

Engine parts used for: MITSUBISHI S4S			
TYPE: Diesel		IN: MITSUBISHI	
4 Cyl.		Nr. 10	
Bore: 94 mm			
PART	REFERENCE	REMARKS	Qty./eng.
	CB 272010		
	VP 272010		
	BB 272010 BM 272010		
	OP 272010 WP 272010		
	NA 272010 NT 272010 KT 272010 IT 272010 HT 272010		
	OF 272010		
	GB 272010		
	IT 272010		

For any other engine parts please contact us! For any other engine parts please contact us!

Ceci n'est qu'une sélection de pièces disponibles dans notre catalogue. Pour toute autre pièce, demandez nous une offre

Engine parts used for: NISSAN			
TYPE: Gasoline		IN: NISSAN	
4 Cyl.		Nr. 5	
Bore: 87,2 mm			
PART	REFERENCE	REMARKS	Qty./eng.
	PI 057005SIDA (STD 025 050 075 100 150) PI 057005SIDB PI 057005SIDC (STD, 050, 100, 150) SE 057005SID (STD, 025, 050, 075, 100, 150)	A: h= 84 mm C: h= 71 mm 	4 4 1
	IK 057005SIDA (STD, 020, 040) IK 057005B UK 057005SIDA (STD, 020, 040) UK 057005B KS 057005A KS 057005B	A: intake: d= 8,6 D= 42 mm B: intake: d= 7 D= 35 mm A: exhaust: d= 8,6 D= 32 mm B: exhaust: d= 7 D= 30 mm A: D = Ø 24 mm B: D = Ø 22 mm	
	HL 057005SIDA (STD, 025, 050, 075, 100) HL 057005SIDB (STD, 025, 050, 075, 100) 1BL 057005SIDA (STD, 025, 050, 075, 100) 1BL 057005SIDB (STD, 012, 025, 050) NL 057005SID (STD, 025, 050, 075) PB 057005	STD shaft dia. 62,955 A= 2x 4x 28 4x 22 62,955 B= 2x 8x 15 51,970 first brg. 45,440 second brg. 43,910 third brg. 41,230	1 8 1 4
	KP 057005A (*, O) KP 057005B (*, O) KP 057005C KP 057005D JC 057005A JC 057005C BP 057005A BP 057005C KA 057005 SV 057005A SV 057005B SV 057005C 1SA 057005A 1SA 057005B SA 057005C KD 057005	A: kit with front oil seal 68 x 45 x 12, with JCA B: kit with front oil seal 95 x 70 x 13, with JCA C: kit with JCC D: kit for H2O PU40 gasket, cylinder head A gasket, cylinder head C gasket kit, valve reg/ind, with JCA gasket kit, valve reg/ind, with JCC valve seals A: oil seal front 68 x 45 x 12 B: oil seal front 95 x 70 x 13 C: oil seal front 82 x 60 x 12 oil seal rear: 2 pcs./ engine oil seal rear: 100 x 80 x 10 gasket valve cover 	

For any other engine parts please contact us!

Engine parts used for: NISSAN H20			
TYPE: Gasoline		IN: NISSAN	
4 Cyl.		TCM	
Bore: 87,2 mm		KOMATSU	
PART	REFERENCE	REMARKS	Qty./eng.
	CB 057005A CB 057005B	103 mm long 109 mm long	
	VP 057005 BB 057005A BB 057005B BM 057005A BM 057005B	3/8 UNF M8 x 1 3/8 UNF M8 x 1	
	OP 057005A OP 057005B WP 057005A WP 057005B WP 057005C RW 057005	 h = 115 mm h = 120 mm	
	NA 057005 NT 057005 KI 057005A KT 057005B KT 057005C KT 057005D HT 057005A HT 057005B	 KTA, KTB, KTC, KTD Holes B: holes thread M6 C: holes thread M8 D: holes thread M6 A: 27 leath B: 23 leath	
	DK 057005A DK 057005B SK 057005	Double chain Single chain KTB, KTC, KTD HTA, HTB HKA, HKB	
	OF 057005A OF 057005B	h = 106 mm h = 100 mm	
	BO 057005A BO 057005B	W16ESU W14EXU	

For any other engine parts please contact us!

PIÈCES POUR MOTEURS THERMIQUES

Pour nos dernières mises à jour catalogue et toute information sur MANUTRANS : www.manutrans.ch

PRÉSENTATION DE NOTRE CATALOGUE DE PIÈCES POUR MOTEURS THERMIQUES

Engine parts used for: PERKINS 4.203			
TYPE: Diesel 4 Cyl. Bore: 91,4 mm		IN: HYSTER, HENLEY, LANSING, ALLIS CHALMERS, CLARK, CATERPILLAR, YALE, LANCER BOSS, FENWICK	
		Nr. 2	
PART	REFERENCE	REMARKS	Qty./eng.
	PI 054002		4
	1SE 054002A 1SE 054002B	A for cast iron liners, rings for 1 piston B for chrome liners, rings for 1 piston	4 4
	CH 054002A CH 054002B CH 054002C AS 054002A AS 054002B AS 054002C	A Cast iron, semi finished B Cast iron, finished C Chrome	4 4 4 4 4 4
	IK 054002A IK 054002B UK 054002A UK 054002B	intake exhaust	
	KS 054002		
	KG 054002 IG 054002 UG 054002	h= 62 mm h= 56,5 mm intake h= 62 mm exhaust	
	HL 054002STD (STD, 010, 020, 030) 1AL 054002STDA (STD, 007) 1AL 054002STDB (STD, 007) 4BL 054002STD (STD, 010, 020, 030) PB 054002	STD shaft dia. 69,812/69,825 A: 1 upper bearing B: 1 lower bearing 57,112/57,125	STD thckn. 3,175 3,175 1 4
	BP 054002A BP 054002B CP 054002 JC 054002A JC 054002B KD 054002A KD 054002B KA 054002 SV 054002 1SA 054002A SA 054002B	A With JCA, gasket kit, valve regrind B With JCB, gasket kit, valve regrind gasket kit bottom A: gasket cylinder head B: gasket cylinder head KDA KDB valve seal oil seal front A: oil seal rear (2 pcs./eng.) ("rope seal") B: oil seal rear ("lip seal")	

For any other engine parts please contact us!

Engine parts used for: PERKINS 4.203			
TYPE: Diesel 4 Cyl. Bore: 91,4 mm		IN: HYSTER, HENLEY, LANSING, ALLIS CHALMERS, CLARK, CATERPILLAR, YALE, LANCER BOSS, FENWICK	
		Nr. 2	
PART	REFERENCE	REMARKS	Qty./eng.
	CG 054002A CG 054002B	A: Short B: Long	
	VP 054002		
	BB 054002 BM 054002		
	OP 054002 WP 054002A RW 054002A WP 054002B RW 054002B WP 054002C RW 054002C WP 054002D RW 054002D	WPA WPC WPB WPD	
	NA 054002		
	NT 054002		
	KT 054002		
	TT 054002A TT 054002B	Lower idler gear, 48 teeth Upper idler gear, 43 teeth	
	OF 054002		
	IT 054002		
	GB 054002A GB 054002B	intake heater intake heater	

For any other engine parts please contact us!

Ceci n'est qu'une sélection de pièces disponibles dans notre catalogue. Pour toute autre pièce, demandez nous une offre

Engine parts used for: TOYOTA 12			
TYPE: Diesel 4 Cyl. Bore: 96 mm		IN: TOYOTA	
		Nr. 3	
PART	REFERENCE	REMARKS	Qty./eng.
	PI 058003STD (STD, 050) SE 058003STD (STD, 050) CH 058003		4 1 4
	IK 058003 UK 058003	intake exhaust	
	KS 058003STD (STD, 005) KG 058003		
	2HL 058003STD HL 058003025 (025, 050, 075, 100) AL 058003STD (STD, 0125, 0250) BL 058003STD 4BL 058003025 (025, 050, 075, 100) PB 058003 NL 058003STDA (STD, 0125, 0250) NL 058003STDB (STD, 0125, 0250)	1 pair of brgs. engine set STD shaft dia. 74,000 STD thckn. 2,43 - 2,48 1 pair of brgs. engine set 55,000 51,170 first bearing (A & B) 50,970 second bearing (A & B) 50,770 third bearing (A & B)	5 1 4 1 4 1 1
	KP 058003 (*, O) BP 058003 KA 058003 SV 058003 SA 058003 KD 058003	overhaul gasket kit gasket kit, valve regrind valve seals oil seal front oil seal rear gasket valve cover (* = With oil-seals (front and rear), (O) = With valve-seals)	

For any other engine parts please contact us!

Engine parts used for: TOYOTA 12			
TYPE: Diesel 4 Cyl. Bore: 96 mm		IN: TOYOTA	
		Nr. 3	
PART	REFERENCE	REMARKS	Qty./eng.
	CB 058003		
	VP 058003		
	BB 058003 BM 058003		
	OP 058003		
	WP 058003		
	NA 058003		
	KT 058003		
	KT 058003		
	TT 058003A TT 058003B HT 058003	d= 50, D= 128, h= 28 mm d= 50, D= 129, h= 30 mm	
	OF 058003		
	IT 058003A IT 058003B	A: DLLA 150P35 B: DLLA 150P602	

For any other engine parts please contact us!

MOTEURS EN ÉCHANGE STANDARD GARANTIS 6 MOIS

MOTEURS NEUFS ET ÉCHANGES STANDARDS

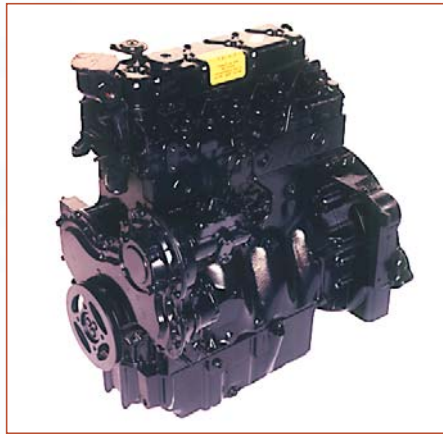
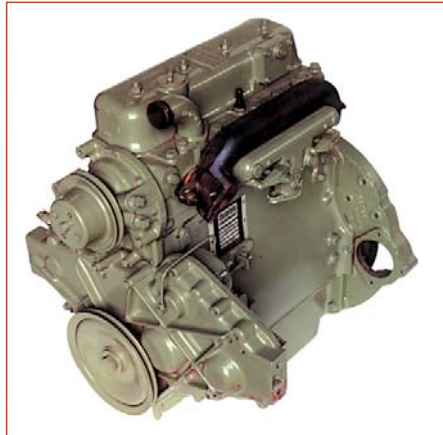
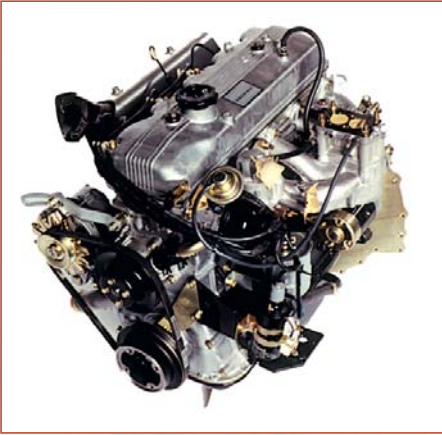

TOYOTA
NISSAN
MITSUBISHI
KOMATSU
ISUZU
MAZDA

CONTINENTAL
PERKINS
WAUKESHA
FORD
GM
CATERPILLAR
CUMMINS
DETROIT
CHRYSLER

DEUTZ
VOLVO
MERCEDES
VOLKSWAGEN
FIAT-OM
PEUGEOT
RENAULT

**Vous souhaitez reconditionner votre moteur ?
Contactez-nous !**

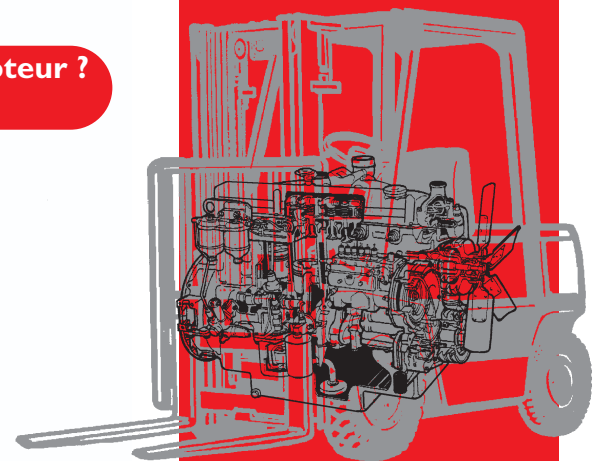

PIÈCES POUR MOTEURS THERMIQUES

Pour nos dernières mises à jour catalogue et toute information sur MANUTRANS : www.manutrans.ch

PIÈCES POUR MOTEURS THERMIQUES RECONDITIONNÉS



TOYOTA
NISSAN
MITSUBISHI
KOMATSU
ISUZU
MAZDA

CONTINENTAL
PERKINS
WAUKESHA
FORD
GM
CATERPILLAR
CUMMINS
DETROIT
CHRYSLER

DEUTZ
VOLVO
MERCEDES
VOLKSWAGEN
FIAT-OM
PEUGEOT
RENAULT

Contactez-nous pour plus d'informations !

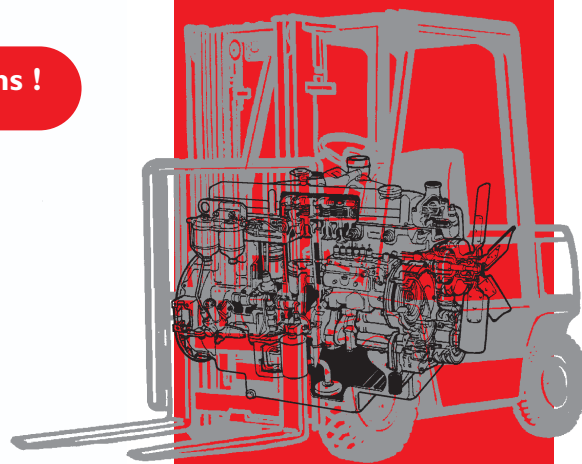

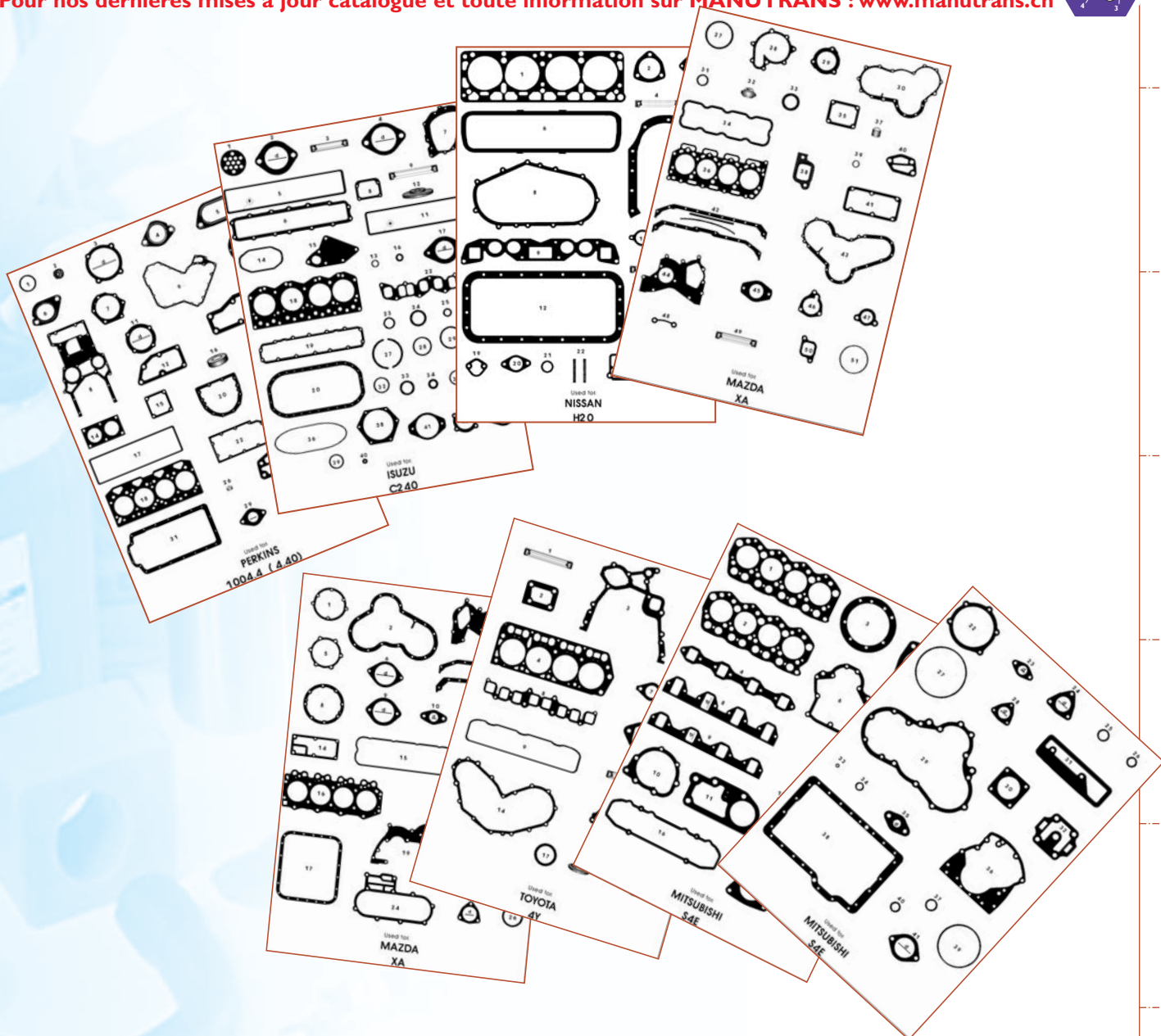

Nous avons en stock des joints de culasse, des joints de cache culbuteurs, des kits de joints haut-moteur et des kits de joints complets (haut et bas-moteur).



CLÉ DYNAMOMÉTRIQUE



Cap. Nm	Longueur mm		
6-30	410	1/4"	REF./ 107TA1661
10-100	490	3/8"	REF./ 107TA1662
40-200	540	1/2"	REF./ 107TA1663
70-340	660	1/2"	REF./ 107TA1664
Douille supplémentaire			
		1/4"	REF./ 107TA1665
		3/8"	REF./ 107TA1666
		1/2"	REF./ 107TA1667

COMPRESSIONMÈTRE

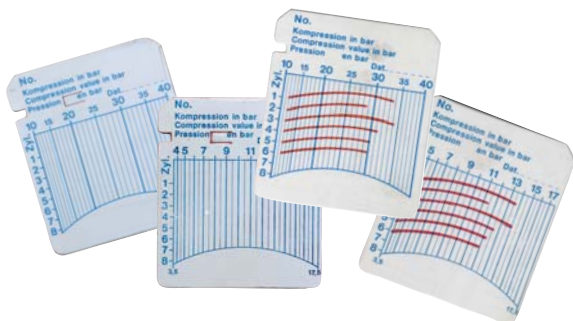

POUR MOTEURS DIESEL

REF./ 106TA6766	kit complet, avec malette
REF./ 106TA6767	indicateur de pression avec tuyau 360mm
REF./ 106TA6768	jeu de 100 cartes de lecture
REF./ 106TA6769	câble de démarrage
REF./ 106TA6770	fixation-rallonge pour les cylindres difficiles d'accès

POUR MOTEURS ESSENCE & GPL

REF./ 107TA7658	kit complet, avec malette
REF./ 107TA7659	indicateur de pression avec tuyau 530mm
REF./ 106TA3063	jeu de 100 cartes de lecture
REF./ 106TA6769	câble de démarrage
REF./ 107TA7660	fixation-rallonge pour les cylindres difficiles d'accès

FICHE TECHNIQUE : JAUGES DE NIVEAU D'HUILE

EXEMPLES



FORMULAIRE À FAXER

Société :

Code client :

Nom :

Numéro de fax :

Marque du chariot / moteur :

Type et n° de série:

FICHE TECHNIQUE

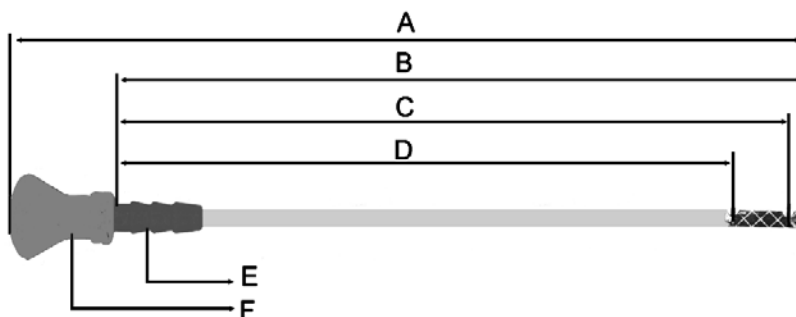

- ① **A = Longueur totale**
- ② **B = Longueur totale sans embout**
- ③ **C = Distance embout-niveau d'huile min. (voir illustration)**
- ④ **D = Distance embout-niveau d'huile max. (voir illustration)**
- ⑤ **E = Diamètre de l'élément de blocage**
- ⑥ **F = Type d'embout (voir ci-dessous)**

TYPE A



Métal plat avec boucle.

TYPE B



Métal rond avec boucle.

TYPE C



En T.

TYPE D



PVC

TYPE E



Fileté

TYPE F



Capuchon de reniflard.

FICHE TECHNIQUE : SOUPAPES D'ADMISSION ET D'ÉCHAPPEMENT

EXEMPLE



FORMULAIRE À FAXER

Société :

Code client :

Nom :

Numéro de fax :

Marque du chariot / moteur :

Type et n° de série:

DIMENSIONS

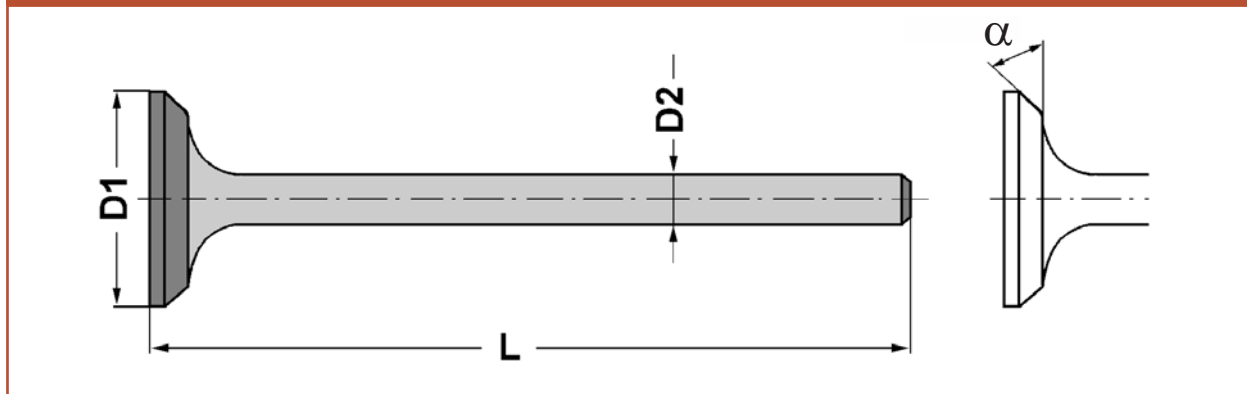

- ① D1 Diamètre de la tête, voir illustration (mm)
- ② D2 Diamètre de la queue, voir illustration (mm)
- ③ L Longueur totale, voir illustration (mm)
- ④ TY-AS Type de queue, voir page suivante
- ⑤ α Angle (alpha), voir illustration, généralement 30° ou 45°

FICHE TECHNIQUE : SOUPAPES D'ADMISSION ET D'ÉCHAPPEMENT

A

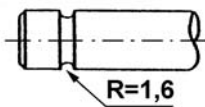

AA

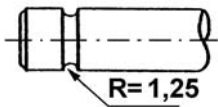

X

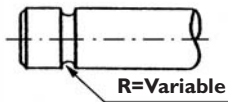

AB

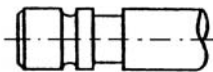

AC

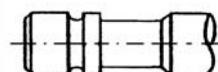

AL

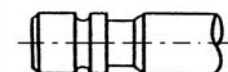

AAA



B

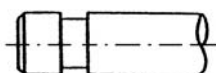

C

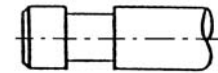

CA

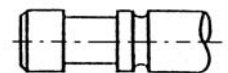

CB

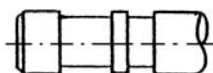

E

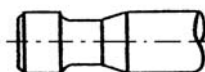

F



FO

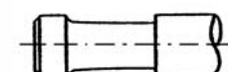

H



I

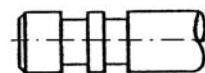

IA

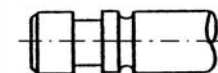

IL



K

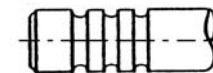

L

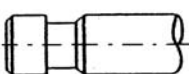

LA

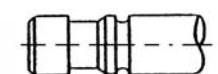

LB

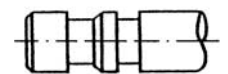

N

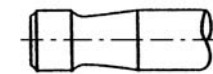

P



Q

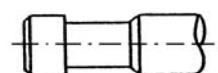

R

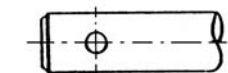

U

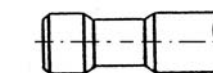

V



Z



LC

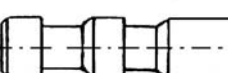

NN

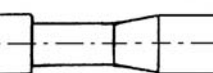

FICHE TECHNIQUE : PASTILLES DE DÉSABLAGE

EXEMPLE : TYPE A



EXEMPLE : TYPE B

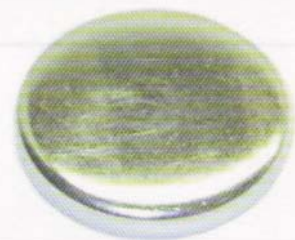

Société :

Code client :

Nom :

Numéro de fax :

Marque du chariot / moteur :

Type et n° de série:

- 1 TY Voir types
- 2 D1-M Diamètre extérieur en mm
- 3 D1-D Diamètre extérieur en pouces (si besoin)
- 4 D2 Voir illustrations : absence de trou possible (mm)
- 5 H Hauteur totale : voir illustrations (mm)

TYPE A

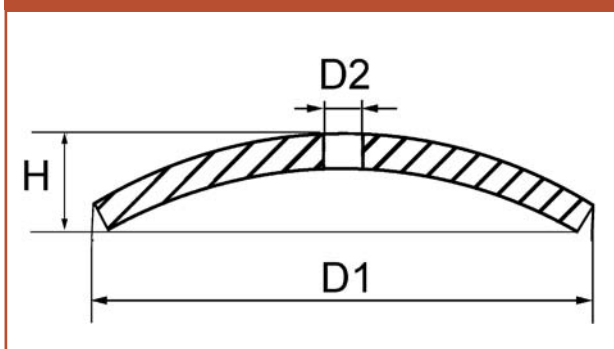

TYPE B

